

P Series PlexPower™ Distribution Panelboards

Increased Safety

Zone 1 and 2 - 21 and 22
Gas (G) and Dust (D)

Applications

- The P Series PlexPower panelboard provides indoor and outdoor protection and control of electrical circuits in hazardous environments such as:
 - Petroleum plants
 - Chemical plants
 - Refineries
 - Other process facilities
- Ideal for placement in wet, corrosive environments or where flammable gases or vapors are likely to be present.
- Suitable for use on lighting, heat trace and power circuits.

Features

- No external conduit or cable seals required thus making installations faster, easier, and less costly.
- Limitless flexibility through horizontal and vertical coupling options.
- The PlexPower panelboard features a ground-breaking design that uses individual breaker housings to minimize the downtime and costs associated with servicing circuit breakers in hazardous locations.
- The lighter weight panelboard enclosure can be quickly opened in the field for easier servicing.
- Supplied as standard:
 - Bottom entries with brass earth plate
 - Pre-drilled supplied with non Ex certified temporary plastic plugs
 - Standard hard wired, copper cables
 - Color coded wiring for phases; neutral (blue) and ground (yellow/green)
 - Internal actuators
 - Internal wiring duct
 - Phenolic nameplate (specify legend)
- Optional gland plate at the bottom of enclosure can be easily field punched or drilled for cable or conduit entries. *See options.*
- 1 circuit to 72 circuit panelboard configurations are standard, with or without main breaker.
- Schneider Ⓢ breakers are supplied as standard, making replacements readily available.
- PlexPower breakers accommodate ABB Ⓜ breakers. For a custom panelboard designed with ABB breakers, contact your local sales representative.
- Branch circuit breakers available in 1-, 2- 3- and 4-pole. Current ratings on branch breakers:
 - 1-pole: 120, 240 Volts, 63 Amps maximum.
 - 2-, 3- and 4-pole: 240 and 415 Volts, 63 Amps maximum.
- Branch breakers are labeled with numbers:
 - Odd numbers for line side
 - Even numbers for load side.
 - Labeled with inside breaker details
- Main circuit breaker:
 - 40 to 250 Amps, 2-, 3- or 4-pole.
- Branch and main breakers can be padlocked in either the “On” or “Off” position.
- Breaker modules supplied with captive bolts.
- Ground bar provided as standard.
- External ground lug provided as standard.



- 240/415 Volt breaker module 8-pole terminal wire range 2.5 mm² through 10 mm² (standard), 16 mm² with special lug.
- 600 Volt main breaker module 4-pole terminal wire range 16 mm² through 150 mm².
- Ambient temperature ratings:
 - Standard model: -25 °C to +55 °C.
 - Standard model without switching: -40 °C

Standard Materials

- Enclosure: fiberglass reinforced polyester (FRP)
- Hardware: stainless steel
- Bus bar: hard drawn copper
- Chassis: hot dip galvanized for wall mounting use

Options

Must be listed in alphanumeric sequence at the end of the catalog number.

- Drain, add suffix —**D**.
- Drain/breather, add suffix —**DV**.
- Gland plate bottom only, specify suffix —**GPP** = plastic gland plate, —**GPB** = brass gland plate.
- Stainless steel legend plate (specify legend), add suffix —**SP**.
- Voltmeter, add suffix —**VM** Ⓢ.
- Ammeter, add suffix —**AM** Ⓢ.
- Cable glands installed, add suffix —**CG**; (cable details to be provided by customer).
- For Ex de IIC, add suffix —**IIC**.
- Optional frame (structure) for floor mounting, self standing with and without canopy, contact your local sales representative for additional information.

Ⓢ Schneider is a registered trademark of Schneider Electric.

Ⓜ ABB Asea Brown Boveri Ltd is registered with the commercial register of Zurich, Switzerland.

Ⓢ Please contact your local sales representative for Voltmeter and Ammeter options.

P Series PlexPower™ Distribution Panelboards

Increased Safety

Zone 1 and 2 - 21 and 22
Gas (G) and Dust (D)

Certifications and Compliances

◆ ATEX/IECEx Certification

• Certification type PlexPower

- Gas: Zones 1 and 2
 - Conforming to ATEX 94/9/EC: Ⓢ II2G
 - Equipment Protection Level: EPL Gb
 - Type of Protection: Ex db eb IIB+H₂
 - Temperature class: T5 for Ta ≤ +40 °C and T4 for +55 °C
- Dust: Zones 21 and 22
 - Conforming to ATEX: Ⓢ II2D
 - Equipment protection level: EPL Db
 - Type of Protection: Ex tb IIIC
 - Surface Temperature: 95°C for Ta ≤ +40 °C and 130 °C for Ta ≤ +55 °C
- Ambient Temperatures:
 - Standard model: -25 °C to +55 °C
 - Standard model without switching: -40 °C to +55 °C
- EC Declaration of Conformity : 50304
- ATEX Certificate: LCIE 13 ATEX 3083X
- IECEx Certificate: IECEx LCIE 13.0073X
- Index of Protection according EN/IEC 60529: IP66
- Impact Resistance: IK10

◆ EURASEC Certification

- EURASEC N° TC RU C-FR.r505.B.00911

◆ Others Certification ①

- Inmetro Certificate: BVC 14.3755-X

① Inmetro certification available on special request only. Contact your local sales for more information.

P Series PlexPower™ Distribution Panelboards

Increased Safety

Zone 1 and 2 - 21 and 22
Gas (G) and Dust (D)

Catalog Numbering Guide ①

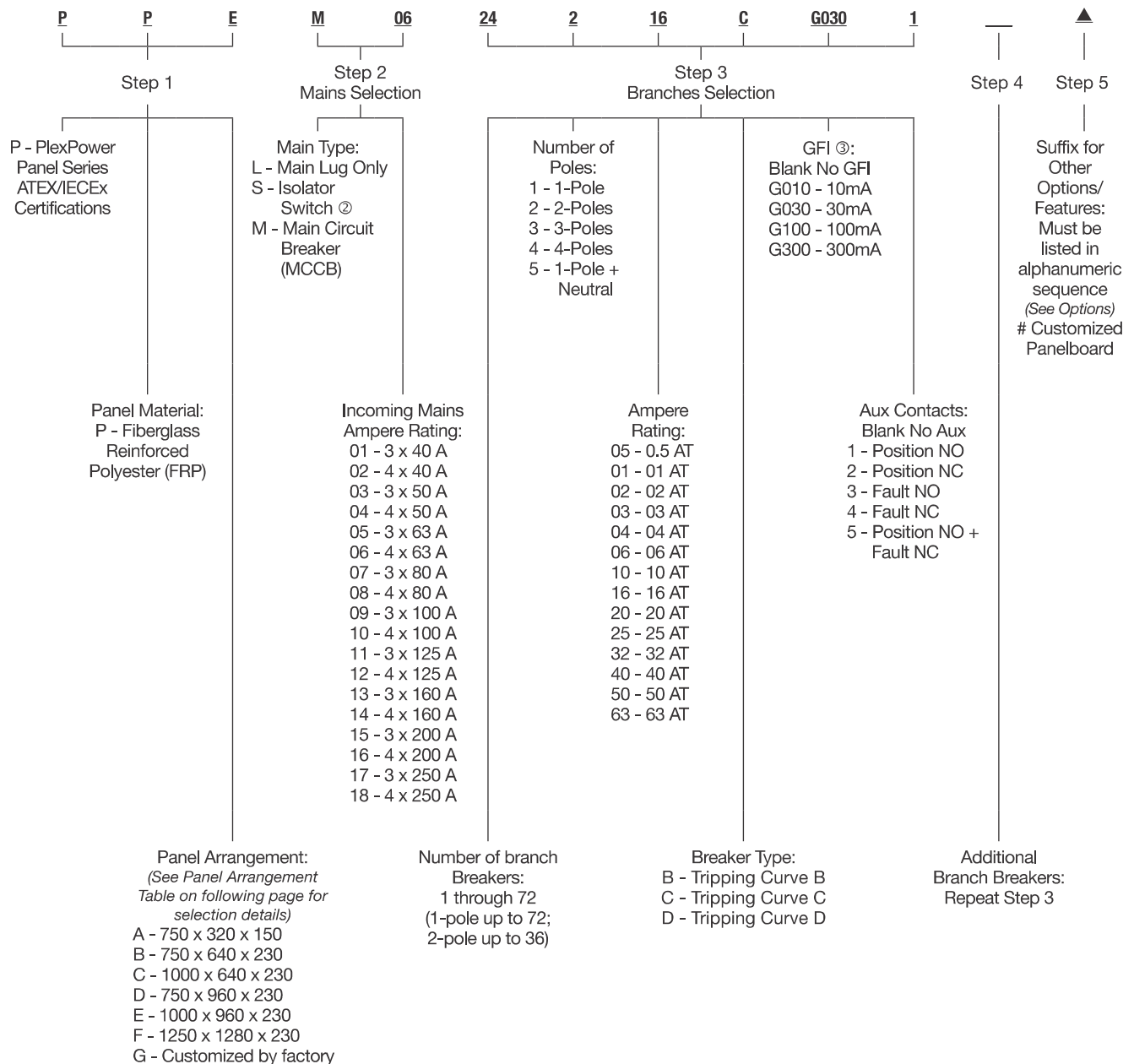

① Please use step by step catalog number on next page.

② Isolators are molded case Switches (MCS).

③ For detailed information see table "Vigi iC60 Add-On Residual Current Devices (RCD or GFI)" on following pages.

P Series PlexPower™ Distribution Panelboards

Increased Safety

Zone 1 and 2 - 21 and 22
Gas (G) and Dust (D)

Steps to Creating Catalog Number:

To create a complete catalog number, refer to the Catalog Numbering Guide on previous page. Product selection information is available within the Guide.

P	P	E	M	06	12	2	16	C	G030	1	▲	—
Step 1		Step 2			Step 3			Step 4		Step 5		

Step 1: Series is P

Material is P

Choose panel arrangement (A, B, C, D, E or F; see drawing at the end of the section for number of circuits).

Step 2: Choose either main lug (L), isolator switch (S) or main circuit breaker (M)

Choose the ampere rating of incoming mains (3 or 4 poles plus ampere: 40, 50, 63, 80, 100, 125, 160, 200, 250)

If a main breaker is desired indicate amperage rating; Example: PPEM06 – 4-pole 63 Amp main breaker.

Step 3: Choose the number of branch breakers

Choose the number of poles

Choose the ampere rating

Choose the breaker type

Choose OPTIONAL GFI

Choose OPTIONAL auxiliary contacts

First digit is the number of branch breakers, second digit is the number of poles, third number is the ampere rating, fourth number is the breaker type and the fifth and six are optional GFI and/or auxiliary contacts; Example: 12216CG0301 is a 2-pole 16 Amp breaker 30 mA GFI with one auxiliary position contact with tripping curve C

Step 4: Repeat Step 3 for as many breaker types are required (please refer to standard configurations)

Step 5: Panel options: Add options in alphanumeric order as listed Options in the Catalog Numbering Guide or Options in the introductory section.

To be Noted When Selecting Panelboards

Entries for Mains Lugs, Isolator Switch, Main Circuit Breaker and Branch circuit breakers are based on rated Amps.

Entries

Incoming Rating	Terminal Size mm ²	AWG	Wire Range mm ²	AWG	Entry Sizes
40 Amp	10	8	1.5 - 16	16-6	M25
50 Amp	16	6	1.5 - 25	14-6	M32
63 Amp	35	2	2.5 - 50	12-2	M32
80 Amp	35	2	2.5 - 50	12-2	M32
100 Amp	50	1/0	10 - 70	10-1/0	M32/M40
125 Amp	50	1/0	10 - 70	10-1/0	M40/M50
160 Amp	70	2/0	10 - 95	8-2/0	M50/M63
200 Amp	120	4/0	16 - 150	4-4/0	M63/M75
250 Amp	120	4/0	16 - 150	4-4/0	M63/M75

Outgoing Branches ①	Terminal Size mm ²	AWG	Wire Range mm ²	AWG	Entry Sizes
20 Amp	6	8	1.5 - 10	22-8	M20
32 Amp	6	8	1.5 - 10	22-8	M25
40 Amp	10	8	1.5 - 16	16-8	M25
50 Amp	16	6	1.5 - 25	14-6	M32
63 Amp	16	6	2.5 - 50	14-6	M32

① All outgoing entries must match respective cable sizes based on outgoing ratings.

P Series PlexPower™ Distribution Panelboards

Increased Safety

Zone 1 and 2 - 21 and 22
Gas (G) and Dust (D)

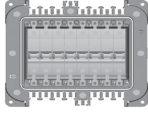
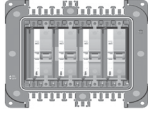
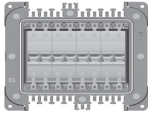
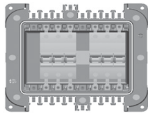
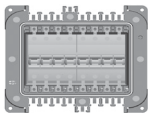
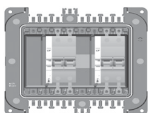
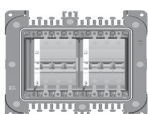
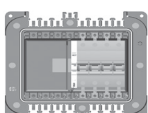
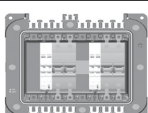
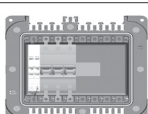
Panel Arrangement Size Selection Guide				
Bus Amps	Volts	Branch Breakers	Circuit configurations	
			8 Pole Module	Maximum no of circuit breaker per 8 Pole Module
63 to 250 A	220/240 V 380/415 V 440 V	1 Pole		8
		1 Poles + Aux (NO or NC)		4
		2 Poles		4
		3 Poles		2
		4 Poles		2
		2 Poles + Aux (NO or NC)		2
		3 Poles + Aux (NO or NC)		2
		4 Poles + Aux (NO or NC)		1
		2 Poles + Aux (NO + NC)		2
		3 Poles + Aux (NO + NC)		1

Distribution Equipment





DISTRIBUTION PANELBOARDS

P Series PlexPower™ Distribution Panelboards

Increased Safety

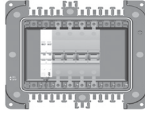
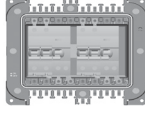
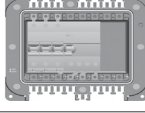
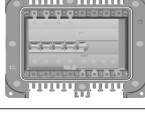
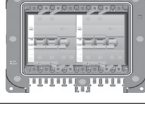
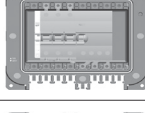
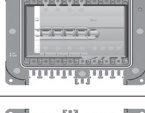
Zone 1 and 2 - 21 and 22
Gas (G) and Dust (D)

Panel Arrangement Size Selection Guide (continued)

Bus Amps	Volts	Branch Breakers	Circuit configurations	
			8 Pole Module	Maximum no of circuit breaker per 8 Pole Module
63 to 250 A	220/240 V 380/415 V 440 V ②	4 Poles + Aux (NO + NC)		1
		2 Poles + GFI		2
		3 Poles + GFI		1
		4 Poles + GFI		1
		2 Poles + GFI + Aux (NO or NC)		2
		3 Poles + GFI + Aux (NO or NC)		1
		4 Poles + GFI + Aux (NO or NC)		1
		2 Poles + GFI + Aux (NO + NC)		1
		3 Poles + GFI + Aux (NO + NC)		1
		4 Poles + GFI + Aux (NO + NC) ①		1

① Up to 25 Amps only.

② 440 V without GFI.

P Series PlexPower™ Distribution Panelboards

Increased Safety

Zone 1 and 2 - 21 and 22
Gas (G) and Dust (D)

Schneider Mains Circuit Breaker (MCCB) Specifications

Common Characteristics

Rated Voltages	Insulation voltage (V)	Ui	800 V	
	Impulse withstand voltage (kV)	Uimp	8 kV	
	Operational voltage (V)	Ue	690 V	AC 50/60 Hz
Compliances	Suitability for isolation		Yes	IEC/EN 60947-2
	Utilisation category		A	
	Pollution degree		3	IEC 60664-1

Breaking Capacity

Circuit Breakers	Breaking Capacity Levels ①	NSX100						NSX160						NSX250											
		B	F	N	H	S	L	R	HB1 ②	HB2	B	F	N	H	S	L	B	F	N	H	S	L	R	HB1 ②	HB2
Rated current (A)	In	100 A						100 A			160 A			250 A			250 A								
Number of poles		2 ③, 3, 4						2 ③, 3, 4			2 ③, 3, 4			2 ③, 3, 4			2 ③, 3, 4								
Breaking capacity (kA rms)																									
Icu AC 50/60 Hz	220/240 V	40	85	90	100	120	150	200	-	-	40	85	90	100	120	150	40	85	90	100	120	150	200	-	-
	380/415 V	25	36	50	70	100	150	200	-	-	25	36	50	70	100	150	25	36	50	70	100	150	200	-	-
	440 V	20	35	50	65	90	130	200	-	-	20	35	50	65	90	130	20	35	50	65	90	130	200	-	-
	500 V	15	25	36	50	65	70	80	85	100	15	30	36	50	65	70	15	30	36	50	65	70	80	85	100
	525 V	-	22	35	35	40	50	65	80	100	-	22	35	35	40	50	-	22	35	35	40	50	65	80	100
	660/690 V	-	8	10	10	15	20	45	75	100	-	8	10	10	15	20	-	8	10	10	15	20	45	75	100
Service breaking capacity (kA rms)																									
Ics AC 50/60 Hz	220/240 V	40	85	90	100	120	150	200	-	-	40	85	90	100	120	150	40	85	90	100	120	150	200	-	-
	380/415 V	25	36	50	70	100	150	200	-	-	25	36	50	70	100	150	25	36	50	70	100	150	200	-	-
	440 V	20	35	50	65	90	130	200	-	-	20	35	50	65	90	130	20	35	50	65	90	130	200	-	-
	500 V	7.5	12.5	36	50	65	70	80	85	100	15	30	36	50	65	70	15	30	36	50	65	70	80	85	100
	525 V	-	11	35	35	40	50	65	80	100	-	22	35	35	40	50	-	22	35	35	40	50	65	80	100
	660/690 V	-	4	10	10	15	20	45	75	100	-	8	10	10	15	20	-	8	10	10	15	20	45	75	100

① Electrical characteristics as per IEC 60947-2.

② There is no 160 A frame, use 250 A frame with lower amperage trip units for R, HB1, HB2.

③ 2P circuit breaker in 3P case for B and F types, only with thermal-magnetic trip unit.

P Series PlexPower™ Distribution Panelboards

Increased Safety

Zone 1 and 2 - 21 and 22
Gas (G) and Dust (D)

Schneider Branch Circuit Breaker Specifications

iC60N Circuit Breakers — Standard Offering — Curve B, C, D

Alternating current (AC) 50/60 Hz — Breaking capacity (Icu)

Ph/Ph (2P, 3P, 4P) Ph/N (1P, 1P+N)	12 to 133 V	Voltage (Ue) ①			Voltage (Ue) ②		Service Breaking Capacity (Ics)
		220 to 240 V	380 to 415 V	440 V	400 V	230 V	
Rating (In)	0.5 to 4 A	50 kA	50 kA	50 kA	25 kA	6 kA	100% of Icu
	6 to 63 A	36 kA	20 kA	10 kA	6 kA	6 kA	75% of Icu

iC60H Circuit Breakers — Optional Offering — Curve B, C, D

Alternating current (AC) 50/60 Hz — Breaking capacity (Icu)

Ph/Ph (2P, 3P, 4P) Ph/N (1P, 1P+N)	12 to 133 V	Voltage (Ue) ①			Voltage (Ue) ②		Service Breaking Capacity (Ics)
		220 to 240 V	380 to 415 V	440 V	400 V	230 V	
Rating (In)	0.5 to 4 A	70 kA	70 kA	70 kA	50 kA	10 kA	100% of Icu
	6 to 63 A	42 kA	30 kA	15 kA	10 kA	10 kA	50% of Icu

iC60L Circuit Breakers — Optional Offering — Curve B, C, K, Z

Alternating current (AC) 50/60 Hz — Breaking capacity (Icu) according to IEC/EN 60947-2

Ph/Ph (2P, 3P, 4P) Ph/N (1P)	12 to 133 V	Voltage (Ue) ①			Voltage (Ue) ②		Service Breaking Capacity (Ics)
		220 to 240 V	380 to 415 V	440 V	400 V	230 V	
Rating (In)	0.5 to 4 A	100 kA	100 kA	100 kA	70 kA	15 kA	100% of Icu
	6 to 25 A	70 kA	50 kA	25 kA	20 kA	15 kA	50% of Icu
	32 to 40 A	70 kA	36 kA	20 kA	15 kA	15 kA	50% of Icu
	50 to 63 A	70 kA	30 kA	15 kA	10 kA	—	50% of Icu

① Breaking capacity (Icu) according to IEC/EN 60947-2.

② Breaking capacity (Icn) according to IEC/EN 60898-1.

P Series PlexPower™ Distribution Panelboards

Increased Safety

Zone 1 and 2 - 21 and 22
Gas (G) and Dust (D)

Schneider Branch Circuit Breaker Specifications (continued)

Vigi iC60 Add-On Residual Current Devices (RCD or GFI) — Optional

Voltage rating (Ue): 230 - 240 V, 400 - 415 V
Operating frequency: 50/60 Hz

	Amps	Sensitivity			
		10 mA	30 mA	300 mA	100 mA
2P	0.5 to 25 A	X	X	X	X
	32 to 40 A	—	X	X	—
	50 to 63 A	—	X	X	X
3P	0.5 to 25 A	—	X	X	—
	32 to 40 A	—	X	X	—
	50 to 63 A	—	X	X	—
4P	0.5 to 25 A	—	X	X	X
	32 to 40 A	—	X	X	—
	50 to 63 A	—	X	X	X

Auxiliary Contact

Maximum	Terminal Size		Wire Range	
	mm ²	AWG	mm ²	AWG
6 Amp	2.5	12	1.5 - 4	26 - 12

P Series PlexPower™ Distribution Panelboards

Increased Safety

Zone 1 and 2 - 21 and 22
Gas (G) and Dust (D)

Cascading — Panelboard Short Circuit Ratings

Upstream: NSX100 — Downstream: iC60 — Ue: 380-415 V (Ph/N 220-240 V)

Upstream			NSX100 NSX100B	NSX100F	NSX100N	NSX100H	NSX100S	NSX100L
Breaking capacity (kA)			25 kA	36 kA	50 kA	70 kA	100 kA	150 kA
Downstream			Reinforced breaking capacity (kA)					
In Max (A)	Icu (kA)							
iC60N	63 A	10 kA	20 kA	25 kA	30 kA	30 kA	30 kA	30 kA
iC60H	40 A	15 kA	25 kA	36 kA	40 kA	40 kA	40 kA	40 kA
	63 A	15 kA	25 kA	36 kA	36 kA	36 kA	36 kA	36 kA
iC60L	25 A	25 kA	—	36 kA	40 kA	40 kA	40 kA	40 kA
	40 A	20 kA	25 kA	36 kA	40 kA	40 kA	40 kA	40 kA
	63 A	15 kA	25 kA	36 kA	36 kA	36 kA	36 kA	36 kA

Upstream: NSX160 — Downstream: C60 — Ue: 380-415 V (Ph/N 220-240 V)

Upstream			NSX160 NSX160B	NSX160F	NSX160N	NSX160H	NSX160S	NSX160L
Breaking capacity (kA)			25 kA	36 kA	50 kA	70 kA	100 kA	150 kA
Downstream			Reinforced breaking capacity (kA)					
In Max (A)	Icu (kA)							
iC60N	63 A	10 kA	20 kA	25 kA	30 kA	30 kA	30 kA	30 kA
iC60H	40 A	15 kA	25 kA	36 kA	40 kA	40 kA	40 kA	40 kA
	63 A	15 kA	25 kA	30 kA	30 kA	30 kA	30 kA	30 kA
iC60L	25 A	25 kA	—	36 kA	40 kA	40 kA	40 kA	40 kA
	40 A	20 kA	25 kA	36 kA	40 kA	40 kA	40 kA	40 kA
	63 A	15 kA	25 kA	30 kA	36 kA	36 kA	36 kA	36 kA

Upstream: NSX250 — Downstream: iC60 — Ue: 380-415 V (Ph/N 220-240 V)

Upstream			NSX250 NSX250B	NSX250F	NSX250N	NSX250H	NSX250S	NSX250L
Breaking capacity (kA)			25 kA	36 kA	50 kA	70 kA	100 kA	150 kA
Downstream			Reinforced breaking capacity (kA)					
In Max (A)	Icu (kA)							
iC60N	40 A	10 kA	20 kA	25 kA	30 kA	30 kA	30 kA	30 kA
	63 A	10 kA	20 kA	25 kA	25 kA	25 kA	25 kA	25 kA
iC60H	40 A	15 kA	25 kA	30 kA	30 kA	30 kA	30 kA	30 kA
	63 A	15 kA	25 kA	25 kA	25 kA	25 kA	25 kA	25 kA
iC60L	25 A	25 kA	—	30 kA	30 kA	30 kA	30 kA	30 kA
	40 A	20 kA	25 kA	30 kA	30 kA	30 kA	30 kA	30 kA
	63 A	15 kA	25 kA	25 kA	25 kA	25 kA	25 kA	25 kA

P Series PlexPower™ Distribution Panelboards

Increased Safety

Zone 1 and 2 - 21 and 22
Gas (G) and Dust (D)

Cascading — Panelboard Short Circuit Ratings (continued)

Upstream: NSX100 — Downstream: iC60 — Ue: 440 V

Upstream		NSX100 NSX100B	NSX100F	NSX100N	NSX100H	NSX100S	NSX100L
Breaking capacity (kA)		20 kA	35 kA	50 kA	65 kA	90 kA	130 kA
Downstream Breaking Capacity (kA)		Reinforced breaking capacity (kA)					
iC60N	6 kA	15 kA	15 kA	20 kA	20 kA	20 kA	20 kA
iC60H	10 kA	20 kA	20 kA	25 kA	25 kA	25 kA	25 kA
iC60L	≤ 25 A	20 kA	—	25 kA	25 kA	25 kA	25 kA
	32-40 A	15 kA	20 kA	20 kA	25 kA	25 kA	25 kA
	50-63 A	10 kA	—	—	—	—	—

Upstream: NSX160 — Downstream: iC60 — Ue: 440 V

Upstream		NSX160 NSX160B	NSX160F	NSX160N	NSX160H	NSX160S	NSX160L
Breaking capacity (kA)		20 kA	35 kA	50 kA	65 kA	90 kA	130 kA
Downstream Breaking Capacity (kA)		Reinforced breaking capacity (kA)					
iC60N	6 kA	15 kA	15 kA	20 kA	20 kA	20 kA	20 kA
iC60H	10 kA	20 kA	20 kA	25 kA	25 kA	25 kA	25 kA
iC60L	≤ 25 A	20 kA	—	25 kA	25 kA	25 kA	25 kA
	32-40 A	15 kA	20 kA	20 kA	25 kA	25 kA	25 kA
	50-63 A	10 kA	—	—	—	—	—

P Series PlexPower™ Distribution Panelboards

Increased Safety

Zone 1 and 2 - 21 and 22
Gas (G) and Dust (D)

Panel Arrangement A

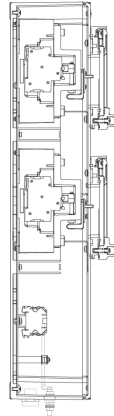
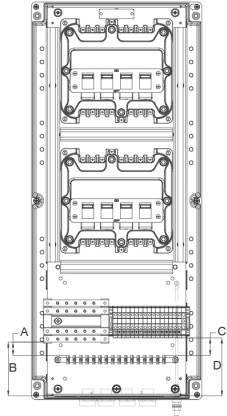
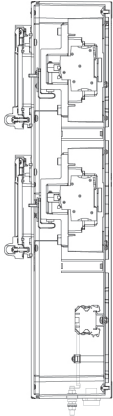

Dimension in Millimeters	
A	26
B	102
C	33
D	109

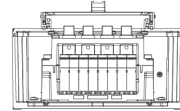

Left Internal View

Front Internal View

Right Internal View

Top Internal View

Breaker Curve C	30mA GFI	Branch Breakers			Circuit Breaker Qty	Main Lugs Only	Armored Entries			Non-Armored Entries		
		1 Position Contact "NO"	1 Trip Contact "NC"				Incoming	Outgoing	Auxiliary	Incoming	Outgoing	Auxiliary
2-Poles 16 Amp	—	—	—	8	4 x 63 Amp	1x M32	8x M20	—	1x M40	8x M20	—	
2-Poles 16 Amp	—	X	—	4	4 x 63 Amp	1x M32	4x M20	1x M20	1x M40	4x M20	1x M25	
2-Poles 16 Amp	—	—	X	4	4 x 63 Amp	1x M32	4x M20	1x M20	1x M40	4x M20	1x M25	
2-Poles 16 Amp	—	X	X	4	4 x 63 Amp	1x M32	4x M20	1x M25	1x M40	4x M20	1x M25	
2-Poles 16 Amp	X	—	—	4	4 x 63 Amp	1x M32	4x M20	—	1x M40	4x M20	—	
2-Poles 16 Amp	X	X	—	4	4 x 63 Amp	1x M32	4x M20	1x M20	1x M40	4x M20	1x M25	
2-Poles 16 Amp	X	—	X	4	4 x 63 Amp	1x M32	4x M20	1x M20	1x M40	4x M20	1x M25	
2-Poles 16 Amp	X	X	X	2	4 x 63 Amp	1x M32	2x M20	1x M25	1x M40	2x M20	1x M25	
3-Poles 16 Amp	—	—	—	4	3 x 63 Amp	1x M32	4x M20	—	1x M40	4x M20	—	
3-Poles 16 Amp	—	X	—	4	3 x 63 Amp	1x M32	4x M20	1x M20	1x M40	4x M20	1x M25	
3-Poles 16 Amp	—	—	X	4	3 x 63 Amp	1x M32	4x M20	1x M20	1x M40	4x M20	1x M25	
3-Poles 16 Amp	—	X	X	2	3 x 63 Amp	1x M32	2x M20	1x M25	1x M40	2x M20	1x M25	
3-Poles 16 Amp	X	—	—	2	3 x 63 Amp	1x M32	2x M20	—	1x M40	2x M20	—	
3-Poles 16 Amp	X	X	—	2	3 x 63 Amp	1x M32	2x M20	1x M20	1x M40	2x M20	1x M25	
3-Poles 16 Amp	X	—	X	2	3 x 63 Amp	1x M32	2x M20	1x M20	1x M40	2x M20	1x M25	
3-Poles 16 Amp	X	X	X	2	3 x 63 Amp	1x M32	2x M20	1x M20	1x M40	2x M20	1x M25	
4-Poles 16 Amp	—	—	—	4	4 x 63 Amp	1x M32	4x M20	—	1x M40	4x M20	—	
4-Poles 16 Amp	—	X	—	2	4 x 63 Amp	1x M32	2x M20	1x M20	1x M40	2x M20	1x M25	
4-Poles 16 Amp	—	—	X	2	4 x 63 Amp	1x M32	2x M20	1x M20	1x M40	2x M20	1x M25	
4-Poles 16 Amp	—	X	X	2	4 x 63 Amp	1x M32	2x M20	1x M20	1x M40	2x M20	1x M25	
4-Poles 16 Amp	X	—	—	2	4 x 63 Amp	1x M32	2x M20	—	1x M40	2x M20	—	
4-Poles 16 Amp	X	X	—	2	4 x 63 Amp	1x M32	2x M20	1x M20	1x M40	2x M20	1x M25	
4-Poles 16 Amp	X	—	X	2	4 x 63 Amp	1x M32	2x M20	1x M20	1x M40	2x M20	1x M25	
4-Poles 16 Amp	X	X	X	2	4 x 63 Amp	1x M32	2x M20	1x M20	1x M40	2x M20	1x M25	

Distribution Equipment

DISTRIBUTION PANELBOARDS

P Series PlexPower™ Distribution Panelboards

Increased Safety

Zone 1 and 2 - 21 and 22
Gas (G) and Dust (D)

Panel Arrangement A

Technical Information			
Panel A Size	750 x 320 x 150 mm		
Panel Weight	40 kg		
Max. No. of Circuits	See Panel Arrangement Size Selection Table		
Voltage	220/240 V, 380/415 V, 440 V		
Wiring	See Wiring Diagram Table		
Breaking Capacity in kA			
	Ratings in Amps	380/415 V	440 V ⑧
Mains	63 A	-	-
Bus-bar	100 A	-	-
Branch Breakers ⑦	0.5 to 4 A	50 kA	25 kA
Branch Breakers ⑦	6 to 63 A	10 kA	6 kA
Panel Arrangement	100 A, 3 Ph, 5 W	-	-

Terminals ①							Non-Armored ⑥	
Incoming		Outgoing		"NO" Position	"NC" Fault		Complete Catalog No	Ordering Catalog No
Qty ②	Size	Qty ③	Size	Qty ④	Qty ⑤	Size		
4	35 mm ²	16	6 mm ²	—	—	—	PPAL068216C	PPAL068216C10N
4	35 mm ²	8	6 mm ²	8	—	2.5 mm ²	PPAL064216C1	PPAL064216C20N
4	35 mm ²	8	6 mm ²	—	2	2.5 mm ²	PPAL064216C4	PPAL064216C30N
4	35 mm ²	8	6 mm ²	8	2	2.5 mm ²	PPAL064216C5	PPAL064216C40N
4	35 mm ²	8	6 mm ²	—	—	—	PPAL064216CG030	PPAL064216C50N
4	35 mm ²	8	6 mm ²	8	—	2.5 mm ²	PPAL064216C1G030	PPAL064216C60N
4	35 mm ²	8	6 mm ²	—	2	2.5 mm ²	PPAL064216C4G030	PPAL064216C70N
4	35 mm ²	4	6 mm ²	8	2	2.5 mm ²	PPAL062216C5G030	PPAL062216C80N
3	35 mm ²	12	6 mm ²	—	—	—	PPAL054316C	PPAL054316C10N
3	35 mm ²	12	6 mm ²	8	—	2.5 mm ²	PPAL054316C1	PPAL054316C20N
3	35 mm ²	12	6 mm ²	—	2	2.5 mm ²	PPAL054316C4	PPAL054316C30N
3	35 mm ²	6	6 mm ²	8	2	2.5 mm ²	PPAL052316C5	PPAL052316C40N
3	35 mm ²	6	6 mm ²	—	—	—	PPAL052316CG030	PPAL052316C50N
3	35 mm ²	6	6 mm ²	4	—	2.5 mm ²	PPAL052316C1G030	PPAL052316C60N
3	35 mm ²	6	6 mm ²	—	2	2.5 mm ²	PPAL052316C4G030	PPAL052316C70N
3	35 mm ²	6	6 mm ²	4	2	2.5 mm ²	PPAL052316C5G030	PPAL052316C80N
4	35 mm ²	16	6 mm ²	—	—	—	PPAL064416C	PPAL064416C10N
4	35 mm ²	8	6 mm ²	4	—	2.5 mm ²	PPAL062416C1	PPAL062416C20N
4	35 mm ²	8	6 mm ²	—	2	2.5 mm ²	PPAL062416C4	PPAL062416C30N
4	35 mm ²	8	6 mm ²	4	2	2.5 mm ²	PPAL062416C5	PPAL062416C40N
4	35 mm ²	8	6 mm ²	—	—	—	PPAL062416CG030	PPAL062416C50N
4	35 mm ²	8	6 mm ²	4	—	2.5 mm ²	PPAL062416C1G030	PPAL062416C60N
4	35 mm ²	8	6 mm ²	—	2	2.5 mm ²	PPAL062416C4G030	PPAL062416C70N
4	35 mm ²	8	6 mm ²	4	2	2.5 mm ²	PPAL062416C5G030	PPAL062416C80N

① Ground bar supplied for each connection.

② Incoming cables terminates directly to the main breaker.

③ Outgoing terminal blocks for branch breakers (provided).

④ Each "NO" position contact are individually terminate on the terminal blocks and in pairs.

⑤ All "NC" trip contacts must be wired in series and terminated on terminal blocks as one pair only.

⑥ For armored version, replace the letter **A** with the letter **N**, in the last position of the Ordering Catalog Number; example: PPBL048216C10A.

⑦ For higher kA rating please consult your local sales representative.

⑧ Without GFI.

P Series PlexPower™ Distribution Panelboards

Increased Safety

Zone 1 and 2 - 21 and 22
Gas (G) and Dust (D)

Panel Arrangement B

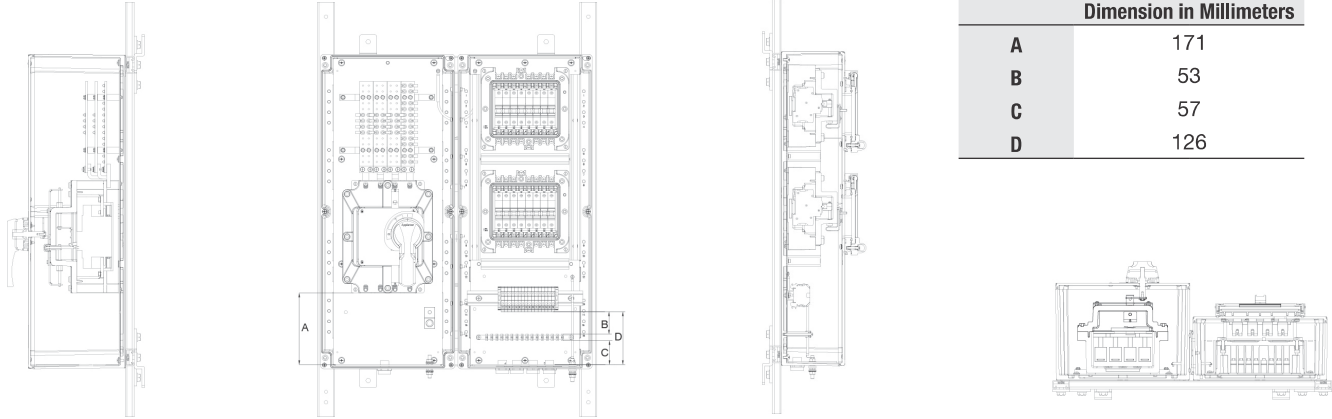

Left Internal View

Front Internal View

Right Internal View

Top Internal View

Breaker Curve C	30mA GFI	Branch Breakers			Main Breaker Size	Armored Entries			Non-Armored Entries		
		1 Position Contact "NO"	1 Trip Contact "NC"	Circuit Breaker Qty		Incoming	Outgoing	Auxiliary	Incoming	Outgoing	Auxiliary
2-Poles 16 Amp	—	—	—	8	4 x 63 Amp	1x M32	8x M20	—	1x M40	8x M20	—
2-Poles 16 Amp	—	X	—	4	4 x 63 Amp	1x M32	4x M20	1x M20	1x M40	4x M20	1x M25
2-Poles 16 Amp	—	—	X	4	4 x 63 Amp	1x M32	4x M20	1x M20	1x M40	4x M20	1x M25
2-Poles 16 Amp	—	X	X	4	4 x 63 Amp	1x M32	4x M20	1x M25	1x M40	4x M20	1x M25
2-Poles 16 Amp	X	—	—	4	4 x 63 Amp	1x M32	4x M20	—	1x M40	4x M20	—
2-Poles 16 Amp	X	X	—	4	4 x 63 Amp	1x M32	4x M20	1x M20	1x M40	4x M20	1x M25
2-Poles 16 Amp	X	—	X	4	4 x 63 Amp	1x M32	4x M20	1x M20	1x M40	4x M20	1x M25
2-Poles 16 Amp	X	X	X	2	4 x 63 Amp	1x M32	2x M20	1x M25	1x M40	2x M20	1x M25
3-Poles 16 Amp	—	—	—	4	3 x 63 Amp	1x M32	4x M20	—	1x M40	4x M20	—
3-Poles 16 Amp	—	X	—	4	3 x 63 Amp	1x M32	4x M20	1x M20	1x M40	4x M20	1x M25
3-Poles 16 Amp	—	—	X	4	3 x 63 Amp	1x M32	4x M20	1x M20	1x M40	4x M20	1x M25
3-Poles 16 Amp	—	X	X	2	3 x 63 Amp	1x M32	2x M20	1x M25	1x M40	2x M20	1x M25
3-Poles 16 Amp	X	—	—	2	3 x 63 Amp	1x M32	2x M20	—	1x M40	2x M20	—
3-Poles 16 Amp	X	X	—	2	3 x 63 Amp	1x M32	2x M20	1x M20	1x M40	2x M20	1x M25
3-Poles 16 Amp	X	—	X	2	3 x 63 Amp	1x M32	2x M20	1x M20	1x M40	2x M20	1x M25
3-Poles 16 Amp	X	X	X	2	3 x 63 Amp	1x M32	2x M20	1x M20	1x M40	2x M20	1x M25
4-Poles 16 Amp	—	—	—	4	4 x 63 Amp	1x M32	4x M20	—	1x M40	4x M20	—
4-Poles 16 Amp	—	X	—	2	4 x 63 Amp	1x M32	2x M20	1x M20	1x M40	2x M20	1x M25
4-Poles 16 Amp	—	—	X	2	4 x 63 Amp	1x M32	2x M20	1x M20	1x M40	2x M20	1x M25
4-Poles 16 Amp	—	X	X	2	4 x 63 Amp	1x M32	2x M20	1x M20	1x M40	2x M20	1x M25
4-Poles 16 Amp	X	—	—	2	4 x 63 Amp	1x M32	2x M20	—	1x M40	2x M20	—
4-Poles 16 Amp	X	X	—	2	4 x 63 Amp	1x M32	2x M20	1x M20	1x M40	2x M20	1x M25
4-Poles 16 Amp	X	—	X	2	4 x 63 Amp	1x M32	2x M20	1x M20	1x M40	2x M20	1x M25
4-Poles 16 Amp	X	X	X	2	4 x 63 Amp	1x M32	2x M20	1x M20	1x M40	2x M20	1x M25

Distribution Equipment

DISTRIBUTION PANELBOARDS

P Series PlexPower™ Distribution Panelboards

Increased Safety

Zone 1 and 2 - 21 and 22
Gas (G) and Dust (D)

Panel Arrangement B			
Technical Information			
Panel B Size	990 x 666 x 230 mm		
Panel Weight	70 kg		
Max. No. of Circuits	See Panel Arrangement Size Selection Table		
Voltage	220/240 V, 380/415 V, 440 V		
Wiring	See Wiring Diagram Table		
Breaking Capacity in kA			
	Ratings in Amps	380/415 V	440 V ⑥
Mains	100 A	25 kA	20 kA
Bus-bar	125 A	50 kA	50 kA
Branch Breakers ⑦	0.5 to 4 A	50 kA	25 kA
Branch Breakers ⑦	6 to 63 A	10 kA	6 kA
Panel Arrangement	100 A, 3 Ph, 5 W	20 kA	15 kA

Terminals ①							Non-Armored ⑥	
Incoming		Outgoing		"NO" Position	"NC" Fault		Complete Catalog No	Ordering Catalog No
Qty ②	Size	Qty ③	Size	Qty ④	Qty ⑤	Size		
4	35 mm ²	16	6 mm ²	—	—	—	PPBM068216C	PPBM068216C10N
4	35 mm ²	8	6 mm ²	8	—	2.5 mm ²	PPBM064216C1	PPBM064216C20N
4	35 mm ²	8	6 mm ²	—	2	2.5 mm ²	PPBM064216C4	PPBM064216C30N
4	35 mm ²	8	6 mm ²	8	2	2.5 mm ²	PPBM064216C5	PPBM064216C40N
4	35 mm ²	8	6 mm ²	—	—	—	PPBM064216CG030	PPBM064216C50N
4	35 mm ²	8	6 mm ²	8	—	2.5 mm ²	PPBM064216C1G030	PPBM064216C60N
4	35 mm ²	8	6 mm ²	—	2	2.5 mm ²	PPBM064216C4G030	PPBM064216C70N
4	35 mm ²	4	6 mm ²	8	2	2.5 mm ²	PPBM062216C5G030	PPBM062216C80N
3	35 mm ²	12	6 mm ²	—	—	—	PPBM054316C	PPBM054316C10N
3	35 mm ²	12	6 mm ²	8	—	2.5 mm ²	PPBM054316C1	PPBM054316C20N
3	35 mm ²	12	6 mm ²	—	2	2.5 mm ²	PPBM054316C4	PPBM054316C30N
3	35 mm ²	6	6 mm ²	8	2	2.5 mm ²	PPBM052316C5	PPBM052316C40N
3	35 mm ²	6	6 mm ²	—	—	—	PPBM052316CG030	PPBM052316C50N
3	35 mm ²	6	6 mm ²	4	—	2.5 mm ²	PPBM052316C1G030	PPBM052316C60N
3	35 mm ²	6	6 mm ²	—	2	2.5 mm ²	PPBM052316C4G030	PPBM052316C70N
3	35 mm ²	6	6 mm ²	4	2	2.5 mm ²	PPBM052316C5G030	PPBM052316C80N
4	35 mm ²	16	6 mm ²	—	—	—	PPBM064416C	PPBM064416C10N
4	35 mm ²	8	6 mm ²	4	—	2.5 mm ²	PPBM062416C1	PPBM062416C20N
4	35 mm ²	8	6 mm ²	—	2	2.5 mm ²	PPBM062416C4	PPBM062416C30N
4	35 mm ²	8	6 mm ²	4	2	2.5 mm ²	PPBM062416C5	PPBM062416C40N
4	35 mm ²	8	6 mm ²	—	—	—	PPBM062416CG030	PPBM062416C50N
4	35 mm ²	8	6 mm ²	4	—	2.5 mm ²	PPBM062416C1G030	PPBM062416C60N
4	35 mm ²	8	6 mm ²	—	2	2.5 mm ²	PPBM062416C4G030	PPBM062416C70N
4	35 mm ²	8	6 mm ²	4	2	2.5 mm ²	PPBM062416C5G030	PPBM062416C80N

① Ground bar supplied for each connection.

② Incoming cables terminates directly to the main breaker.

③ Outgoing terminal blocks for branch breakers (provided).

④ Each "NO" position contact are individually terminate on the terminal blocks and in pairs.

⑤ All "NC" trip contacts must be wired in series and terminated on terminal blocks as one pair only.

⑥ For armored version, replace the letter **A** with the letter **N**, in the last position of the Ordering Catalog Number; example: PPBM048216C10A.

⑦ For higher kA rating please consult your local sales representative.

⑧ Without GFI.

P Series PlexPower™ Distribution Panelboards

Increased Safety

Zone 1 and 2 - 21 and 22
Gas (G) and Dust (D)

Panel Arrangement C

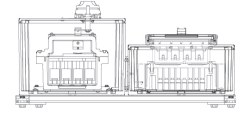
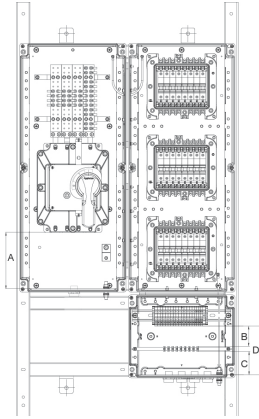
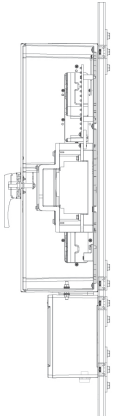

Dimension in Millimeters	
A	170
B	61
C	70
D	147

Left Internal View

Front Internal View

Right Internal View

Top Internal View

Breaker Curve C	Branch Breakers				Main Breaker Size	Armored Entries			Non-Armored Entries		
	30mA GFI	1 Position Contact "NO"	1 Trip Contact "NC"	Circuit Breaker Qty		Incoming	Outgoing	Auxiliary	Incoming	Outgoing	Auxiliary
2-Poles 16 Amp	—	—	—	12	4 x 125 Amp	1x M40	12 xM20	—	1x M40	12 xM20	—
2-Poles 16 Amp	—	X	—	6	4 x 63 Amp	1x M32	6 xM20	1x M25	1x M40	6 xM20	1x M25
2-Poles 16 Amp	—	—	X	6	4 x 63 Amp	1x M32	6 xM20	1x M20	1x M40	6 xM20	1x M25
2-Poles 16 Amp	—	X	X	6	4 x 63 Amp	1x M32	6 xM20	1x M25	1x M40	6 xM20	1x M25
2-Poles 16 Amp	X	—	—	6	4 x 63 Amp	1x M32	6 xM20	—	1x M40	6 xM20	—
2-Poles 16 Amp	X	X	—	6	4 x 63 Amp	1x M32	6 xM20	1x M20	1x M40	6 xM20	1x M25
2-Poles 16 Amp	X	—	X	6	4 x 63 Amp	1x M32	6 xM20	1x M20	1x M40	6 xM20	1x M25
2-Poles 16 Amp	X	X	X	3	4 x 63 Amp	1x M32	3 xM20	1x M20	1x M40	3 xM20	1x M25
3-Poles 16 Amp	—	—	—	6	3 x 63 Amp	1x M32	6 xM20	—	1x M40	6 xM20	—
3-Poles 16 Amp	—	X	—	6	3 x 63 Amp	1x M32	6 xM20	1x M25	1x M40	6 xM20	1x M25
3-Poles 16 Amp	—	—	X	6	3 x 63 Amp	1x M32	6 xM20	1x M20	1x M40	6 xM20	1x M25
3-Poles 16 Amp	—	X	X	3	3 x 63 Amp	1x M32	3 xM20	1x M20	1x M40	3 xM20	1x M25
3-Poles 16 Amp	X	—	—	3	3 x 63 Amp	1x M32	3 xM20	—	1x M40	3 xM20	—
3-Poles 16 Amp	X	X	—	3	3 x 63 Amp	1x M32	3 xM20	1x M20	1x M40	3 xM20	1x M25
3-Poles 16 Amp	X	—	X	3	3 x 63 Amp	1x M32	3 xM20	1x M20	1x M40	3 xM20	1x M25
3-Poles 16 Amp	X	X	X	3	3 x 63 Amp	1x M32	3 xM20	1x M20	1x M40	3 xM20	1x M25
4-Poles 16 Amp	—	—	—	6	4 x 63 Amp	1x M32	6 xM20	—	1x M40	6 xM20	—
4-Poles 16 Amp	—	X	—	3	4 x 63 Amp	1x M32	3 xM20	1x M20	1x M40	3 xM20	1x M25
4-Poles 16 Amp	—	—	X	3	4 x 63 Amp	1x M32	3 xM20	1x M20	1x M40	3 xM20	1x M25
4-Poles 16 Amp	—	X	X	3	4 x 63 Amp	1x M32	3 xM20	1x M20	1x M40	3 xM20	1x M25
4-Poles 16 Amp	X	—	—	3	4 x 63 Amp	1x M32	3 xM20	—	1x M40	3 xM20	—
4-Poles 16 Amp	X	X	—	3	4 x 63 Amp	1x M32	3 xM20	1x M20	1x M40	3 xM20	1x M25
4-Poles 16 Amp	X	—	X	3	4 x 63 Amp	1x M32	3 xM20	1x M20	1x M40	3 xM20	1x M25
4-Poles 16 Amp	X	X	X	3	4 x 63 Amp	1x M32	3 xM20	1x M20	1x M40	3 xM20	1x M25

Distribution Equipment

DISTRIBUTION PANELBOARDS

P Series PlexPower™ Distribution Panelboards

Increased Safety

Zone 1 and 2 - 21 and 22
Gas (G) and Dust (D)

Panel Arrangement C			
Technical Information			
Panel C Size	1250 x 666 x 230 mm		
Panel Weight	80 kg		
Max. No. of Circuits	See Panel Arrangement Size Selection Table		
Voltage	220/240 V, 380/415 V, 440 V		
Wiring	See Wiring Diagram Table		
Breaking Capacity in kA			
	Ratings in Amps	380/415 V	440 V ⑥
Mains	125 A	25 kA	20 kA
Bus-bar	125 A	50 kA	50 kA
Branch Breakers ⑦	0.5 to 4 A	50 kA	25 kA
Branch Breakers ⑦	6 to 63 A	10 kA	6 kA
Panel Arrangement	125 A, 3 Ph, 5 W	20 kA	15 kA

Incoming		Outgoing		Terminals ①		Non-Armored ⑥		
Qty ②	Size	Qty ③	Size	"NO" Position Qty ④	"NC" Fault Qty ⑤	Size	Complete Catalog No	Ordering Catalog No
4	50 mm ²	24	6 mm ²	—	—	—	PPCM1212216C	PPCM1212216C10N
4	35 mm ²	12	6 mm ²	12	—	2.5 mm ²	PPCM066216C1	PPCM066216C20N
4	35 mm ²	12	6 mm ²	—	2	2.5 mm ²	PPCM066216C4	PPCM066216C30N
4	35 mm ²	12	6 mm ²	12	2	2.5 mm ²	PPCM066216C5	PPCM066216C40N
4	35 mm ²	12	6 mm ²	—	—	—	PPCM066216CG030	PPCM066216C50N
4	35 mm ²	12	6 mm ²	12	—	2.5 mm ²	PPCM066216C1G030	PPCM066216C60N
4	35 mm ²	12	6 mm ²	—	2	2.5 mm ²	PPCM066216C4G030	PPCM066216C70N
4	35 mm ²	6	6 mm ²	12	2	2.5 mm ²	PPCM063216C5G030	PPCM063216C80N
3	35 mm ²	18	6 mm ²	—	—	—	PPCM056316C	PPCM056316C10N
3	35 mm ²	18	6 mm ²	12	—	2.5 mm ²	PPCM056316C1	PPCM056316C20N
3	35 mm ²	18	6 mm ²	—	2	2.5 mm ²	PPCM056316C4	PPCM056316C30N
3	35 mm ²	9	6 mm ²	6	2	2.5 mm ²	PPCM053316C5	PPCM053316C40N
3	35 mm ²	9	6 mm ²	—	—	—	PPCM053316CG030	PPCM053316C50N
3	35 mm ²	9	6 mm ²	6	—	2.5 mm ²	PPCM053316C1G030	PPCM053316C60N
3	35 mm ²	9	6 mm ²	—	2	2.5 mm ²	PPCM053316C4G030	PPCM053316C70N
3	35 mm ²	9	6 mm ²	6	2	2.5 mm ²	PPCM053316C5G030	PPCM053316C80N
4	35 mm ²	24	6 mm ²	—	—	—	PPCM066416C	PPCM066416C10N
4	35 mm ²	12	6 mm ²	6	—	2.5 mm ²	PPCM063416C1	PPCM063416C20N
4	35 mm ²	12	6 mm ²	—	2	2.5 mm ²	PPCM063416C4	PPCM063416C30N
4	35 mm ²	12	6 mm ²	6	2	2.5 mm ²	PPCM063416C5	PPCM063416C40N
4	35 mm ²	12	6 mm ²	—	—	—	PPCM063416CG030	PPCM063416C50N
4	35 mm ²	12	6 mm ²	6	—	2.5 mm ²	PPCM063416C1G030	PPCM063416C60N
4	35 mm ²	12	6 mm ²	—	2	2.5 mm ²	PPCM063416C4G030	PPCM063416C70N
4	35 mm ²	12	6 mm ²	6	2	2.5 mm ²	PPCM063416C5G030	PPCM063416C80N

① Ground bar supplied for each connection.

② Incoming cables terminates directly to the main breaker.

③ Outgoing terminal blocks for branch breakers (provided).

④ Each "NO" position contact are individually terminate on the terminal blocks and in pairs.

⑤ All "NC" trip contacts must be wired in series and terminated on terminal blocks as one pair only.

⑥ For armored version, replace the letter **A** with the letter **N**, in the last position of the Ordering Catalog Number; example: PPCM0812216C10A.

⑦ For higher kA rating please consult your local sales representative.

⑧ Without GFI.

P Series PlexPower™ Distribution Panelboards

Increased Safety

Zone 1 and 2 - 21 and 22
Gas (G) and Dust (D)

Panel Arrangement D

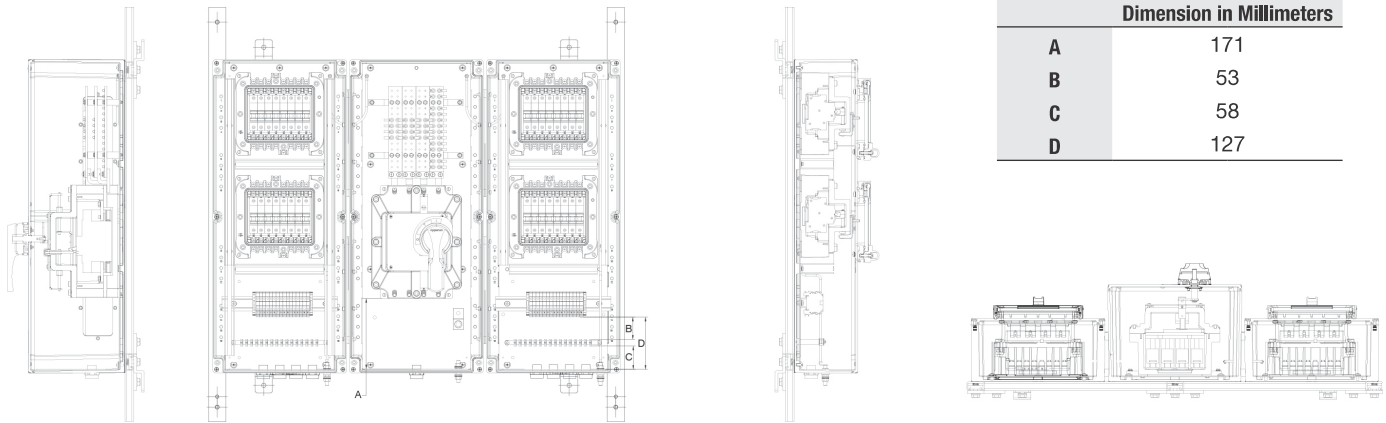

Left Internal View

Front Internal View

Right Internal View

Top Internal View

Breaker Curve C	30mA GFI	Branch Breakers			Main Breaker Size	Armored Entries			Non-Armored Entries		
		1 Position Contact "NO"	1 Trip Contact "NC"	Circuit Breaker Qty		Incoming	Outgoing	Auxiliary	Incoming	Outgoing	Auxiliary
2-Poles 16 Amp	—	—	—	16	4 x 160 Amp	1x M50	16 xM20	—	1x M50	16 xM20	—
2-Poles 16 Amp	—	X	—	8	4 x 100 Amp	1x M40	8 xM20	1x M25	1x M40	8 xM20	1x M25
2-Poles 16 Amp	—	—	X	8	4 x 100 Amp	1x M40	8 xM20	1x M20	1x M40	8 xM20	1x M25
2-Poles 16 Amp	—	X	X	8	4 x 100 Amp	1x M40	8 xM20	1x M25	1x M40	8 xM20	1x M25
2-Poles 16 Amp	X	—	—	8	4 x 100 Amp	1x M40	8 xM20	—	1x M40	8 xM20	—
2-Poles 16 Amp	X	X	—	8	4 x 100 Amp	1x M40	8 xM20	1x M25	1x M40	8 xM20	1x M25
2-Poles 16 Amp	X	—	X	8	4 x 100 Amp	1x M40	8 xM20	1x M20	1x M40	8 xM20	1x M25
2-Poles 16 Amp	X	X	X	4	4 x 63 Amp	1x M32	4 xM20	1x M25	1x M40	4 xM20	1x M25
3-Poles 16 Amp	—	—	—	8	3 x 100 Amp	1x M40	8 xM20	—	1x M40	8 xM20	—
3-Poles 16 Amp	—	X	—	8	3 x 100 Amp	1x M40	8 xM20	1x M25	1x M40	8 xM20	1x M25
3-Poles 16 Amp	—	—	X	8	3 x 100 Amp	1x M40	8 xM20	1x M20	1x M40	8 xM20	1x M25
3-Poles 16 Amp	—	X	X	4	3 x 63 Amp	1x M32	4 xM20	1x M25	1x M40	4 xM20	1x M25
3-Poles 16 Amp	X	—	—	4	3 x 63 Amp	1x M32	4 xM20	—	1x M40	4 xM20	—
3-Poles 16 Amp	X	X	—	4	3 x 63 Amp	1x M32	4 xM20	1x M20	1x M40	4 xM20	1x M25
3-Poles 16 Amp	X	—	X	4	3 x 63 Amp	1x M32	4 xM20	1x M20	1x M40	4 xM20	1x M25
3-Poles 16 Amp	X	X	X	4	3 x 63 Amp	1x M32	4 xM20	1x M25	1x M40	4 xM20	1x M25
4-Poles 16 Amp	—	—	—	8	4 x 63 Amp	1x M32	8 xM20	—	1x M40	8 xM20	—
4-Poles 16 Amp	—	X	—	4	4 x 63 Amp	1x M32	4 xM20	1x M20	1x M40	4 xM20	1x M25
4-Poles 16 Amp	—	—	X	4	4 x 63 Amp	1x M32	4 xM20	1x M20	1x M40	4 xM20	1x M25
4-Poles 16 Amp	—	X	X	4	4 x 63 Amp	1x M32	4 xM20	1x M25	1x M40	4 xM20	1x M25
4-Poles 16 Amp	X	—	—	4	4 x 63 Amp	1x M32	4 xM20	—	1x M40	4 xM20	—
4-Poles 16 Amp	X	X	—	4	4 x 63 Amp	1x M32	4 xM20	1x M20	1x M40	4 xM20	1x M25
4-Poles 16 Amp	X	—	X	4	4 x 63 Amp	1x M32	4 xM20	1x M20	1x M40	4 xM20	1x M25
4-Poles 16 Amp	X	X	X	4	4 x 63 Amp	1x M32	4 xM20	1x M25	1x M40	4 xM20	1x M25

Distribution Equipment

DISTRIBUTION PANELBOARDS

P Series PlexPower™ Distribution Panelboards

Increased Safety

Zone 1 and 2 - 21 and 22
Gas (G) and Dust (D)

Panel Arrangement D			
Technical Information			
Panel D Size	990 x 994 x 230 mm		
Panel Weight	120 kg		
Max. No. of Circuits	See Panel Arrangement Size Selection Table		
Voltage	220/240 V, 380/415 V, 440 V		
Wiring	See Wiring Diagram Table		
Breaking Capacity in kA			
	Ratings in Amps	380/415 V	440 V ⑧
Mains	160 A	25 kA	20 kA
Bus-bar	160 A	50 kA	50 kA
Branch Breakers ⑦	0.5 to 4 A	50 kA	25 kA
Branch Breakers ⑦	6 to 63 A	10 kA	6 kA
Panel Arrangement	160 A, 3 Ph, 5 W	20 kA	15 kA

Incoming		Outgoing		"NO" Position	"NC" Fault	Size	Non-Armored ⑥	
Qty ②	Size	Qty ③	Size	Qty ④	Qty ⑤		Complete Catalog No	Ordering Catalog No
4	70 mm ²	32	6 mm ²	—	—	—	PPDM1416216C	PPDM1416216C10N
4	50 mm ²	16	6 mm ²	16	—	2.5 mm ²	PPDM108216C1	PPDM108216C20N
4	50 mm ²	16	6 mm ²	—	2	2.5 mm ²	PPDM108216C4	PPDM108216C30N
4	50 mm ²	16	6 mm ²	16	2	2.5 mm ²	PPDM108216C5	PPDM108216C40N
4	50 mm ²	16	6 mm ²	—	—	—	PPDM108216CG030	PPDM108216C50N
4	50 mm ²	16	6 mm ²	16	—	2.5 mm ²	PPDM108216C1G030	PPDM108216C60N
4	50 mm ²	16	6 mm ²	—	2	2.5 mm ²	PPDM108216C4G030	PPDM108216C70N
4	35 mm ²	8	6 mm ²	8	2	2.5 mm ²	PPDM064216C5G030	PPDM064216C80N
3	50 mm ²	24	6 mm ²	—	—	—	PPDM098316C	PPDM098316C10N
3	50 mm ²	24	6 mm ²	16	—	2.5 mm ²	PPDM098316C1	PPDM098316C20N
3	50 mm ²	24	6 mm ²	—	2	2.5 mm ²	PPDM098316C4	PPDM098316C30N
3	35 mm ²	12	6 mm ²	8	2	2.5 mm ²	PPDM054316C5	PPDM054316C40N
3	35 mm ²	12	6 mm ²	—	—	—	PPDM054316CG030	PPDM054316C50N
3	35 mm ²	12	6 mm ²	8	—	2.5 mm ²	PPDM054316C1G030	PPDM054316C60N
3	35 mm ²	12	6 mm ²	—	2	2.5 mm ²	PPDM054316C4G030	PPDM054316C70N
3	35 mm ²	12	6 mm ²	8	2	2.5 mm ²	PPDM054316C5G030	PPDM054316C80N
4	35 mm ²	32	6 mm ²	—	—	—	PPDM068416C	PPDM068416C10N
4	35 mm ²	16	6 mm ²	8	—	2.5 mm ²	PPDM064416C1	PPDM064416C20N
4	35 mm ²	16	6 mm ²	—	2	2.5 mm ²	PPDM064416C4	PPDM064416C30N
4	35 mm ²	16	6 mm ²	8	2	2.5 mm ²	PPDM064416C5	PPDM064416C40N
4	35 mm ²	16	6 mm ²	—	—	—	PPDM064416CG030	PPDM064416C50N
4	35 mm ²	16	6 mm ²	8	—	2.5 mm ²	PPDM064416C1G030	PPDM064416C60N
4	35 mm ²	16	6 mm ²	—	2	2.5 mm ²	PPDM064416C4G030	PPDM064416C70N
4	35 mm ²	16	6 mm ²	8	2	2.5 mm ²	PPDM064416C5G030	PPDM064416C80N

① Ground bar supplied for each connection.

② Incoming cables terminates directly to the main breaker.

③ Outgoing terminal blocks for branch breakers (provided).

④ Each "NO" position contact are individually terminate on the terminal blocks and in pairs.

⑤ All "NC" trip contacts must be wired in series and terminated on terminal blocks as one pair only.

⑥ For armored version, replace the letter **A** with the letter **N**, in the last position of the Ordering Catalog Number; example: PPDM1016216C10A.

⑦ For higher kA rating please consult your local sales representative.

⑧ Without GFI.

P Series PlexPower™ Distribution Panelboards

Increased Safety

Zone 1 and 2 - 21 and 22
Gas (G) and Dust (D)

Panel Arrangement E

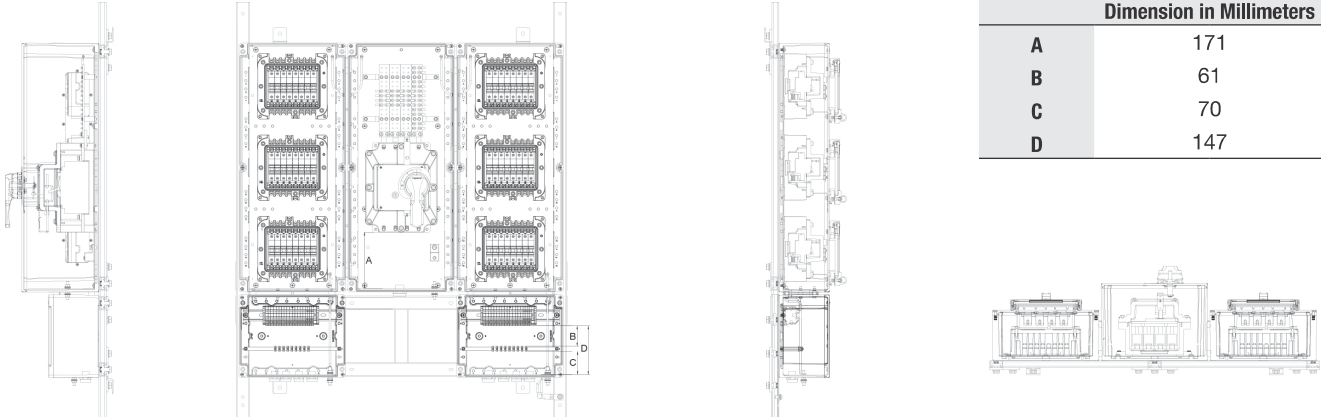

Left Internal View

Front Internal View

Right Internal View

Top Internal View

Breaker Curve C	30mA GFI	Branch Breakers			Main Breaker Size	Armored Entries			Non-Armored Entries		
		1 Position Contact "NO"	1 Trip Contact "NC"	Circuit Breaker Qty		Incoming	Outgoing	Auxiliary	Incoming	Outgoing	Auxiliary
2-Poles 16 Amp	—	—	—	24	4 x 200 Amp	1x M63	24x M20	—	1x M63	24x M20	—
2-Poles 16 Amp	—	X	—	12	4 x 125 Amp	1x M40	12x M20	1x M32	1x M40	12x M20	1x M32
2-Poles 16 Amp	—	—	X	12	4 x 125 Amp	1x M40	12x M20	1x M20	1x M40	12x M20	1x M25
2-Poles 16 Amp	—	X	X	12	4 x 125 Amp	1x M40	12x M20	1x M32	1x M40	12x M20	1x M32
2-Poles 16 Amp	X	—	—	12	4 x 125 Amp	1x M40	12x M20	—	1x M40	12x M20	—
2-Poles 16 Amp	X	X	—	12	4 x 125 Amp	1x M40	12x M20	1x M32	1x M40	12x M20	1x M32
2-Poles 16 Amp	X	—	X	12	4 x 125 Amp	1x M40	12x M20	1x M20	1x M40	12x M20	1x M25
2-Poles 16 Amp	X	X	X	6	4 x 63 Amp	1x M32	6x M20	1x M25	1x M40	6x M20	1x M25
3-Poles 16 Amp	—	—	—	12	3 x 125 Amp	1x M40	12x M20	—	1x M40	12x M20	—
3-Poles 16 Amp	—	X	—	12	3 x 125 Amp	1x M40	12x M20	1x M32	1x M40	12x M20	1x M32
3-Poles 16 Amp	—	—	X	12	3 x 125 Amp	1x M40	12x M20	1x M20	1x M40	12x M20	1x M25
3-Poles 16 Amp	—	X	X	6	3 x 63 Amp	1x M32	6x M20	1x M25	1x M40	6x M20	1x M25
3-Poles 16 Amp	X	—	—	6	3 x 63 Amp	1x M32	6x M20	—	1x M40	6x M20	—
3-Poles 16 Amp	X	X	—	6	3 x 63 Amp	1x M32	6x M20	1x M25	1x M40	6x M20	1x M25
3-Poles 16 Amp	X	—	X	6	3 x 63 Amp	1x M32	6x M20	1x M20	1x M40	6x M20	1x M25
3-Poles 16 Amp	X	X	X	6	3 x 63 Amp	1x M32	6x M20	1x M25	1x M40	6x M20	1x M25
4-Poles 16 Amp	—	—	—	12	4 x 63 Amp	1x M32	12x M20	—	1x M40	12x M20	—
4-Poles 16 Amp	—	X	—	6	4 x 63 Amp	1x M32	6x M20	1x M25	1x M40	6x M20	1x M25
4-Poles 16 Amp	—	—	X	6	4 x 63 Amp	1x M32	6x M20	1x M20	1x M40	6x M20	1x M25
4-Poles 16 Amp	—	X	X	6	4 x 63 Amp	1x M32	6x M20	1x M25	1x M40	6x M20	1x M25
4-Poles 16 Amp	X	—	—	6	4 x 63 Amp	1x M32	6x M20	—	1x M40	6x M20	—
4-Poles 16 Amp	X	X	—	6	4 x 63 Amp	1x M32	6x M20	1x M25	1x M40	6x M20	1x M25
4-Poles 16 Amp	X	—	X	6	4 x 63 Amp	1x M32	6x M20	1x M20	1x M40	6x M20	1x M25
4-Poles 16 Amp	X	X	X	6	4 x 63 Amp	1x M32	6x M20	1x M25	1x M40	6x M20	1x M25

DISTRIBUTION PANELBOARDS

P Series PlexPower™ Distribution Panelboards

Increased Safety

Zone 1 and 2 - 21 and 22
Gas (G) and Dust (D)

Panel Arrangement E			
Technical Information			
Panel E Size	1250 x 994 x 230 mm		
Panel Weight	145 kg		
Max. No. of Circuits	See Panel Arrangement Size Selection Table		
Voltage	220/240 V, 380/415 V, 440 V		
Wiring	See Wiring Diagram Table		
Breaking Capacity in kA			
	Ratings in Amps	380/415 V	440 V ⑧
Mains	200 A	25 kA	20 kA
Bus-bar	250 A	50 kA	50 kA
Branch Breakers ⑦	0.5 to 4 A	50 kA	25 kA
Branch Breakers ⑦	6 to 63 A	10 kA	6 kA
Panel Arrangement	200 A, 3 Ph, 5 W	20 kA	-

Terminals ①							Non-Armored ⑥	
Incoming		Outgoing		"NO" Position	"NC" Fault		Complete Catalog No	Ordering Catalog No
Qty ②	Size	Qty ③	Size	Qty ④	Qty ⑤	Size		
4	120 mm ²	48	6 mm ²	—	—	—	PPEM1624216C	PPEM1624216C10N
4	50 mm ²	24	6 mm ²	24	—	2.5 mm ²	PPEM1212216C1	PPEM1212216C20N
4	50 mm ²	24	6 mm ²	—	2	2.5 mm ²	PPEM1212216C4	PPEM1212216C30N
4	50 mm ²	24	6 mm ²	24	2	2.5 mm ²	PPEM1212216C5	PPEM1212216C40N
4	50 mm ²	24	6 mm ²	—	—	—	PPEM1212216CG030	PPEM1212216C50N
4	50 mm ²	24	6 mm ²	24	—	2.5 mm ²	PPEM1212216C1G030	PPEM1212216C60N
4	50 mm ²	24	6 mm ²	—	2	2.5 mm ²	PPEM1212216C4G030	PPEM1212216C70N
4	35 mm ²	12	6 mm ²	12	2	2.5 mm ²	PPEM066216C5G030	PPEM066216C80N
3	50 mm ²	24	6 mm ²	—	—	—	PPEM1112316C	PPEM1112316C10N
3	50 mm ²	24	6 mm ²	24	—	2.5 mm ²	PPEM1112316C1	PPEM1112316C20N
3	50 mm ²	24	6 mm ²	—	2	2.5 mm ²	PPEM1112316C4	PPEM1112316C30N
3	35 mm ²	18	6 mm ²	12	2	2.5 mm ²	PPEM056316C5	PPEM056316C40N
3	35 mm ²	18	6 mm ²	—	—	—	PPEM056316CG030	PPEM056316C50N
3	35 mm ²	18	6 mm ²	12	—	2.5 mm ²	PPEM056316C1G030	PPEM056316C60N
3	35 mm ²	18	6 mm ²	—	2	2.5 mm ²	PPEM056316C4G030	PPEM056316C70N
3	35 mm ²	18	6 mm ²	12	2	2.5 mm ²	PPEM056316C5G030	PPEM056316C80N
4	35 mm ²	48	6 mm ²	—	—	—	PPEM0612416C	PPEM0612416C10N
4	35 mm ²	24	6 mm ²	12	—	2.5 mm ²	PPEM066416C1	PPEM066416C20N
4	35 mm ²	24	6 mm ²	—	2	2.5 mm ²	PPEM066416C4	PPEM066416C30N
4	35 mm ²	24	6 mm ²	12	2	2.5 mm ²	PPEM066416C5	PPEM066416C40N
4	35 mm ²	24	6 mm ²	—	—	—	PPEM066416CG030	PPEM066416C50N
4	35 mm ²	24	6 mm ²	12	—	2.5 mm ²	PPEM066416C1G030	PPEM066416C60N
4	35 mm ²	24	6 mm ²	—	2	2.5 mm ²	PPEM066416C4G030	PPEM066416C70N
4	35 mm ²	24	6 mm ²	12	2	2.5 mm ²	PPEM066416C5G030	PPEM066416C80N

① Ground bar supplied for each connection.

② Incoming cables terminates directly to the main breaker.

③ Outgoing terminal blocks for branch breakers (provided).

④ Each "NO" position contact are individually terminate on the terminal blocks and in pairs.

⑤ All "NC" trip contacts must be wired in series and terminated on terminal blocks as one pair only.

⑥ For armored version, replace the letter **A** with the letter **N**, in the last position of the Ordering Catalog Number; example: PPEM1224216C10A.

⑦ For higher kA rating please consult your local sales representative.

⑧ Without GFI.

P Series PlexPower™ Distribution Panelboards

Increased Safety

Zone 1 and 2 - 21 and 22
Gas (G) and Dust (D)

Panel Arrangement F

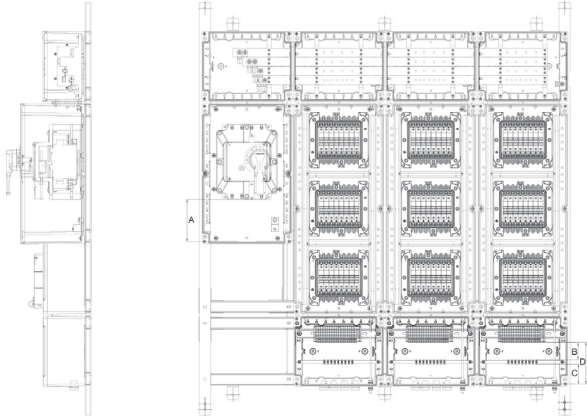

Dimension in Millimeters	
A	150
B	61
C	70
D	147

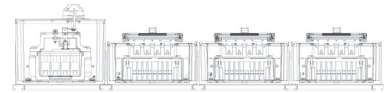

Left Internal View

Front Internal View

Right Internal View

Top Internal View

Breaker Curve C	30mA GFI	Branch Breakers			Main Breaker Size	Armored Entries			Non-Armored Entries		
		1 Position Contact "NO"	1 Trip Contact "NC"	Circuit Breaker Qty		Incoming	Outgoing	Auxiliary	Incoming	Outgoing	Auxiliary
2-Poles 16 Amp	—	—	—	36	4 x 250 Amp	1x M63	36 xM20	—	1x M63	36 xM20	—
2-Poles 16 Amp	—	X	—	18	4 x 200 Amp	1x M63	18 xM20	1x M32	1x M63	18 xM20	1x M40
2-Poles 16 Amp	—	—	X	18	4 x 200 Amp	1x M63	18 xM20	1x M20	1x M63	18 xM20	1x M25
2-Poles 16 Amp	—	X	X	18	4 x 200 Amp	1x M63	18 xM20	1x M32	1x M63	18 xM20	1x M40
2-Poles 16 Amp	X	—	—	18	4 x 200 Amp	1x M63	18 xM20	—	1x M63	18 xM20	—
2-Poles 16 Amp	X	X	—	18	4 x 200 Amp	1x M63	18 xM20	1x M32	1x M63	18 xM20	1x M40
2-Poles 16 Amp	X	—	X	18	4 x 200 Amp	1x M63	18 xM20	1x M20	1x M63	18 xM20	1x M25
2-Poles 16 Amp	X	X	X	9	4 x 100 Amp	1x M40	9 xM20	1x M32	1x M40	9 xM20	1x M25
3-Poles 16 Amp	—	—	—	18	3 x 200 Amp	1x M63	18 xM20	—	1x M63	18 xM20	—
3-Poles 16 Amp	—	X	—	18	3 x 200 Amp	1x M63	18 xM20	1x M32	1x M63	18 xM20	1x M40
3-Poles 16 Amp	—	—	X	18	3 x 200 Amp	1x M63	18 xM20	1x M20	1x M63	18 xM20	1x M25
3-Poles 16 Amp	—	X	X	9	3 x 100 Amp	1x M40	9 xM20	1x M32	1x M40	9 xM20	1x M25
3-Poles 16 Amp	X	—	—	9	3 x 100 Amp	1x M40	9 xM20	—	1x M40	9 xM20	—
3-Poles 16 Amp	X	X	—	9	3 x 100 Amp	1x M40	9 xM20	1x M25	1x M40	9 xM20	1x M25
3-Poles 16 Amp	X	—	X	9	3 x 100 Amp	1x M40	9 xM20	1x M20	1x M40	9 xM20	1x M25
3-Poles 16 Amp	X	X	X	9	3 x 100 Amp	1x M40	9 xM20	1x M32	1x M40	9 xM20	1x M25
4-Poles 16 Amp	—	—	—	18	4 x 200 Amp	1x M63	18 xM20	—	1x M63	18 xM20	—
4-Poles 16 Amp	—	X	—	9	4 x 100 Amp	1x M40	9 xM20	1x M25	1x M40	9 xM20	1x M25
4-Poles 16 Amp	—	—	X	9	4 x 100 Amp	1x M40	9 xM20	1x M20	1x M40	9 xM20	1x M25
4-Poles 16 Amp	—	X	X	9	4 x 100 Amp	1x M40	9 xM20	1x M32	1x M40	9 xM20	1x M25
4-Poles 16 Amp	X	—	—	9	4 x 100 Amp	1x M40	9 xM20	—	1x M40	9 xM20	—
4-Poles 16 Amp	X	X	—	9	4 x 100 Amp	1x M40	9 xM20	1x M25	1x M40	9 xM20	1x M25
4-Poles 16 Amp	X	—	X	9	4 x 100 Amp	1x M40	9 xM20	1x M20	1x M40	9 xM20	1x M25
4-Poles 16 Amp	X	X	X	9	4 x 100 Amp	1x M40	9 xM20	1x M32	1x M40	9 xM20	1x M25

Distribution Equipment

DISTRIBUTION PANELBOARDS

P Series PlexPower™ Distribution Panelboards

Increased Safety

Zone 1 and 2 - 21 and 22
Gas (G) and Dust (D)

Panel Arrangement F

Technical Information			
Panel A Size	1470 x 1323 x 230 mm		
Panel Weight	200 kg		
Max. No. of Circuits	See Panel Arrangement Size Selection Table		
Voltage	220/240 V, 380/415 V, 440 V		
Wiring	See Wiring Diagram Table		
Breaking Capacity in kA			
	Ratings in Amps	380/415 V	440 V ⑧
Mains	250 A	25 kA	20 kA
Bus-bar	250 A	50 kA	50 kA
Branch Breakers ⑦	0.5 to 4 A	50 kA	25 kA
Branch Breakers ⑦	6 to 63 A	10 kA	6 kA
Panel Arrangement	250 A, 3 Ph, 5 W	20 kA	-

Terminals ①							Non-Armored ⑥	
Incoming		Outgoing		"NO" Position	"NC" Fault	Size	Complete Catalog No	Ordering Catalog No
Qty ②	Size	Qty ③	Size	Qty ④	Qty ⑤	Size		
4	120 mm ²	72	6 mm ²	—	—	—	PPFM1836216C	PPFM1836216C10N
4	120 mm ²	36	6 mm ²	36	—	2.5 mm ²	PPFM1618216C1	PPFM1618216C20N
4	120 mm ²	36	6 mm ²	—	2	2.5 mm ²	PPFM1618216C4	PPFM1618216C30N
4	120 mm ²	36	6 mm ²	36	2	2.5 mm ²	PPFM1618216C5	PPFM1618216C40N
4	120 mm ²	36	6 mm ²	—	—	—	PPFM1618216CG030	PPFM1618216C50N
4	120 mm ²	36	6 mm ²	36	—	2.5 mm ²	PPFM1618216C1G030	PPFM1618216C60N
4	120 mm ²	36	6 mm ²	—	2	2.5 mm ²	PPFM1618216C4G030	PPFM1618216C70N
4	50 mm ²	18	6 mm ²	18	2	2.5 mm ²	PPFM109216C5G030	PPFM109216C80N
3	120 mm ²	36	6 mm ²	—	—	—	PPFM1518316C	PPFM1518316C10N
3	120 mm ²	36	6 mm ²	36	—	2.5 mm ²	PPFM1518316C1	PPFM1518316C20N
3	120 mm ²	36	6 mm ²	—	2	2.5 mm ²	PPFM1518316C4	PPFM1518316C30N
3	50 mm ²	18	6 mm ²	18	2	2.5 mm ²	PPFM099316C5	PPFM099316C40N
3	50 mm ²	18	6 mm ²	—	—	—	PPFM099316CG030	PPFM099316C50N
3	50 mm ²	18	6 mm ²	18	—	2.5 mm ²	PPFM099316C1G030	PPFM099316C60N
3	50 mm ²	18	6 mm ²	—	2	2.5 mm ²	PPFM099316C4G030	PPFM099316C70N
3	50 mm ²	18	6 mm ²	18	2	2.5 mm ²	PPFM099316C5G030	PPFM099316C80N
4	120 mm ²	36	6 mm ²	—	—	—	PPFM1618416C	PPFM1618416C10N
4	50 mm ²	18	6 mm ²	18	—	2.5 mm ²	PPFM109416C1	PPFM109416C20N
4	50 mm ²	18	6 mm ²	—	2	2.5 mm ²	PPFM109416C4	PPFM109416C30N
4	50 mm ²	18	6 mm ²	18	2	2.5 mm ²	PPFM109416C5	PPFM109416C40N
4	50 mm ²	18	6 mm ²	—	—	—	PPFM109416CG030	PPFM109416C50N
4	50 mm ²	18	6 mm ²	18	—	2.5 mm ²	PPFM109416C1G030	PPFM109416C60N
4	50 mm ²	18	6 mm ²	—	2	2.5 mm ²	PPFM109416C4G030	PPFM109416C70N
4	50 mm ²	18	6 mm ²	18	2	2.5 mm ²	PPFM109416C5G030	PPFM109416C80N

① Ground bar supplied for each connection.

② Incoming cables terminate directly to the main breaker.

③ Outgoing terminal blocks for branch breakers (provided).

④ Each "NO" position contact are individually terminate on the terminal blocks and in pairs.

⑤ All "NC" trip contacts must be wired in series and terminated on terminal blocks as one pair only.

⑥ For armored version, replace the letter **A** with the letter **N**, in the last position of the Ordering Catalog Number; example: PPFM1436216C10A.

⑦ For higher kA rating please consult your local sales representative.

⑧ Without GFI.

P Series PlexPower™ Distribution Panelboards

Increased Safety

Zone 1 and 2 - 21 and 22
Gas (G) and Dust (D)

Wiring Diagrams — Panel Arrangements B, C, D, E, F — For Panel Arrangement A, Remove Main Breaker from Wiring Diagrams

Q1: Main Breaker
M1-M8: Module Housing
D1-▲: MCB

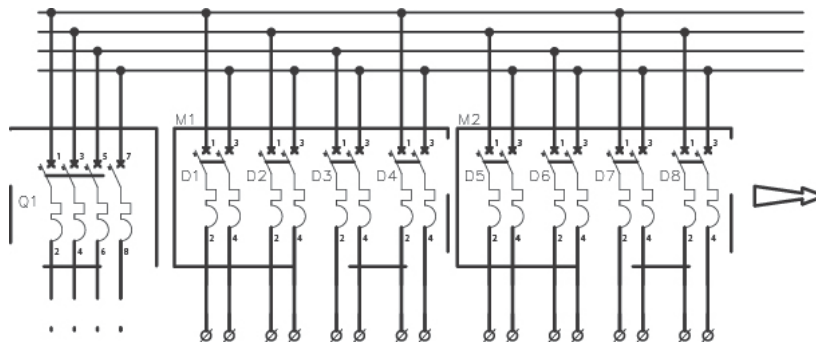

2-Pole

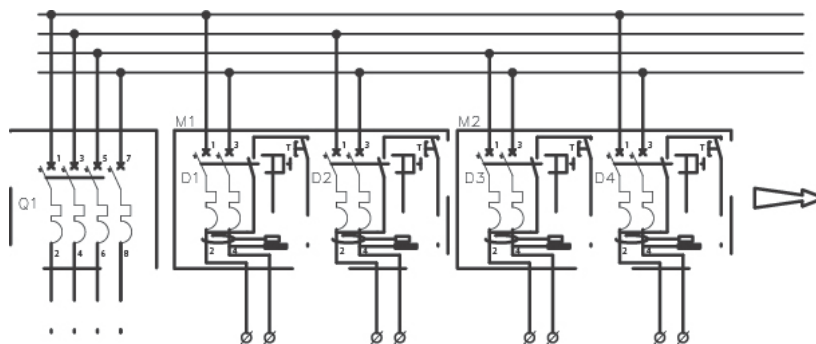

2-Pole + GFI

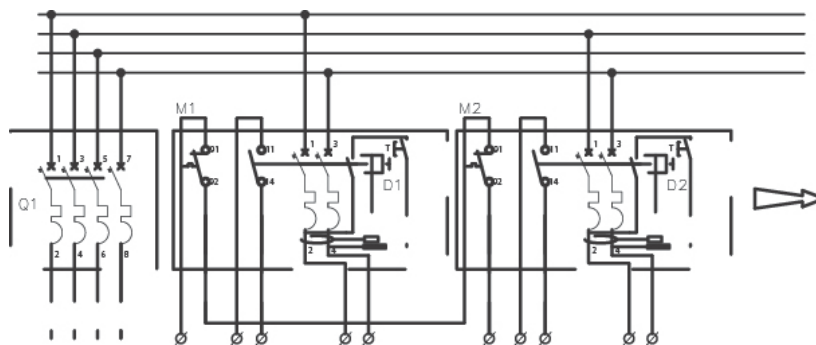

2-Pole + GFI + AUX NO + AUX NC

▲ Number of branch circuit breakers will depend on the number of module housing.

P Series PlexPower™ Distribution Panelboards

Increased Safety

Zone 1 and 2 - 21 and 22
Gas (G) and Dust (D)

Standard Panel Arrangement Layout — Dimensions in Millimeters

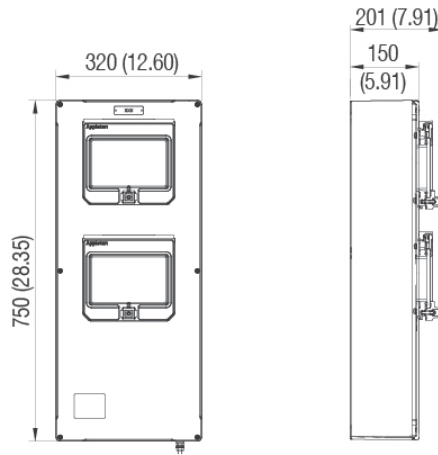

Panel Arrangement A

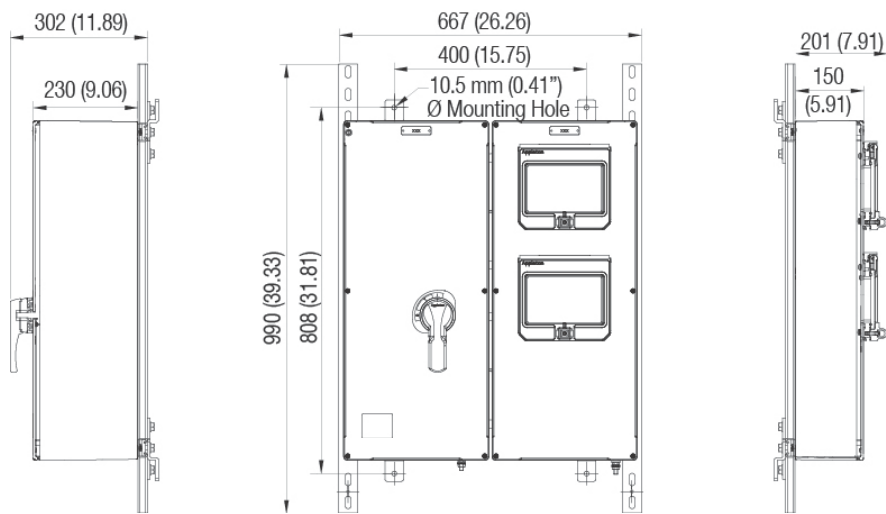

Panel Arrangement B

Distribution Equipment

DISTRIBUTION PANELBOARDS

P Series PlexPower™ Distribution Panelboards

Increased Safety

Zone 1 and 2 - 21 and 22
Gas (G) and Dust (D)

Standard Panel Arrangement Layout – Dimensions in Millimeters

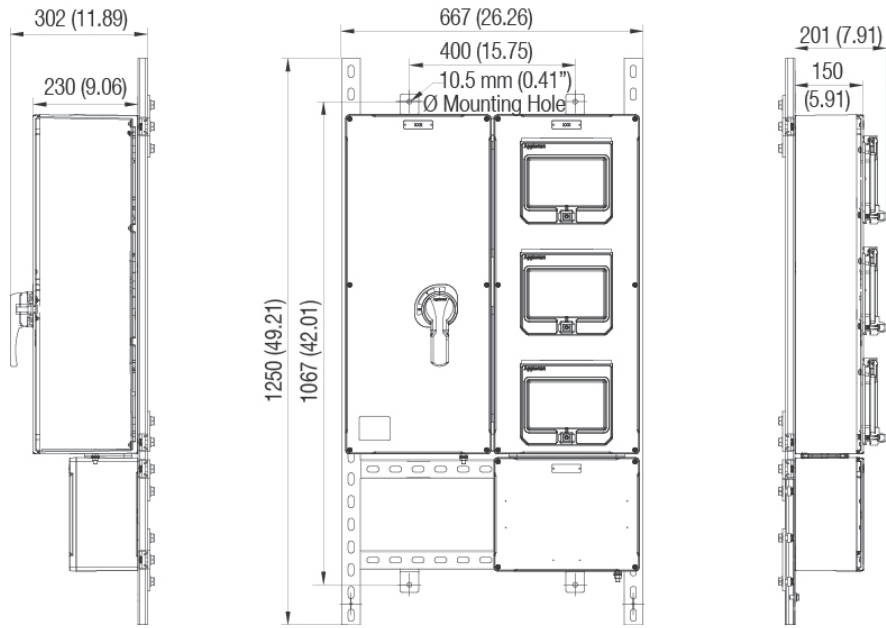

Panel Arrangement C

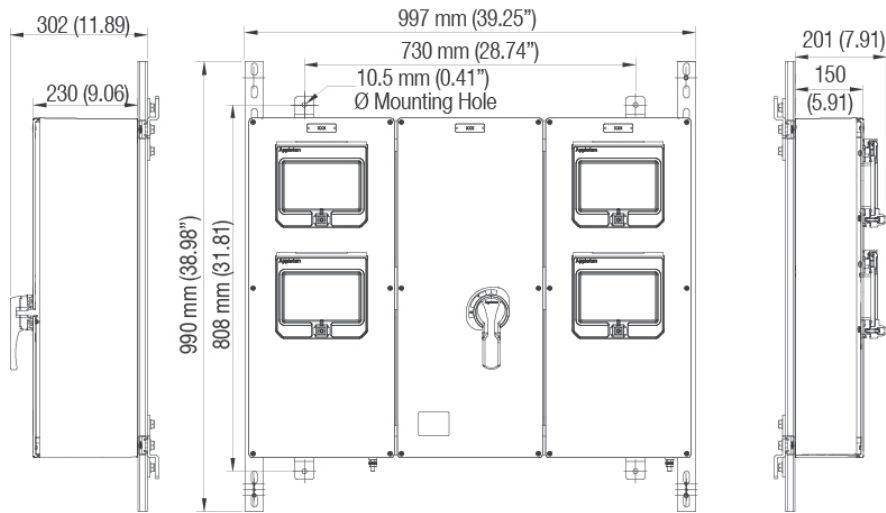

Panel Arrangement D

Distribution Equipment

DISTRIBUTION PANELBOARDS

P Series PlexPower™ Distribution Panelboards

Increased Safety

Zone 1 and 2 - 21 and 22
Gas (G) and Dust (D)

Standard Panel Arrangement Layout — Dimensions in Millimeters

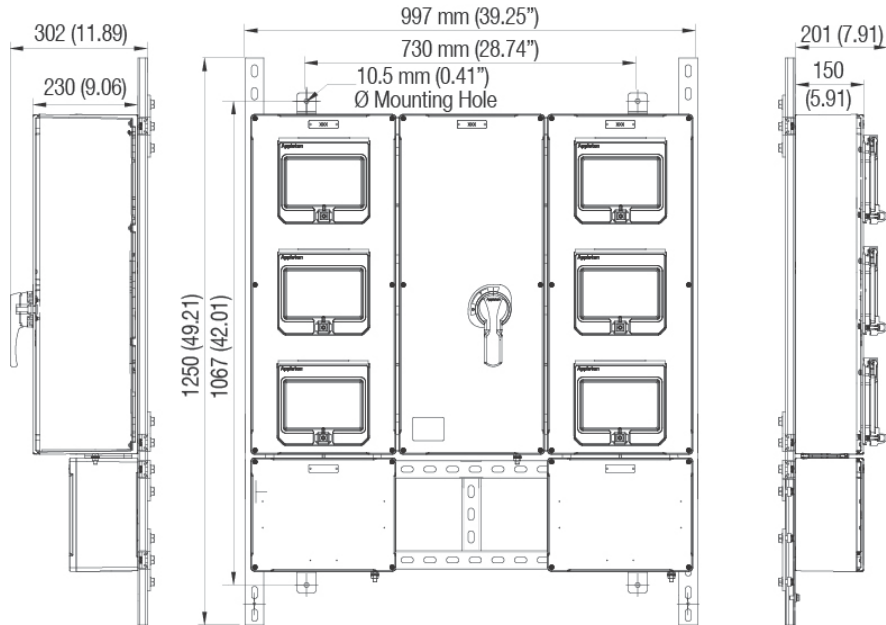

Panel Arrangement E

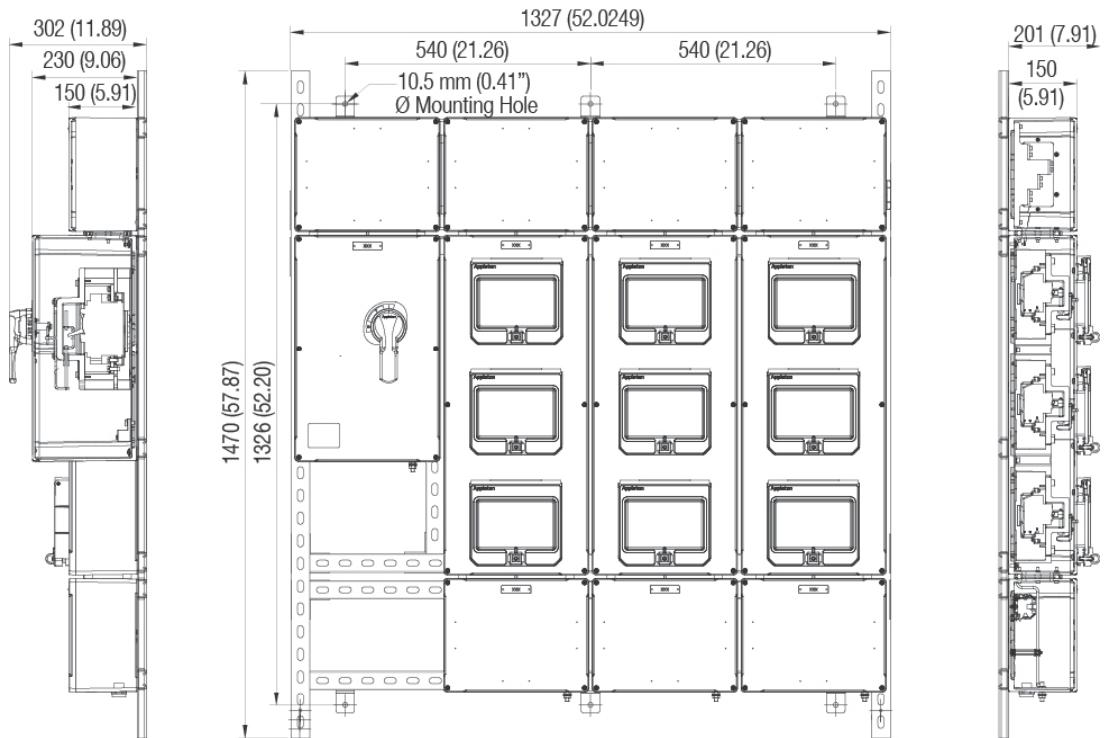

Panel Arrangement F

Distribution Equipment

DISTRIBUTION PANELBOARDS